

Positioning system ALLZ 203, 204

Belt drive

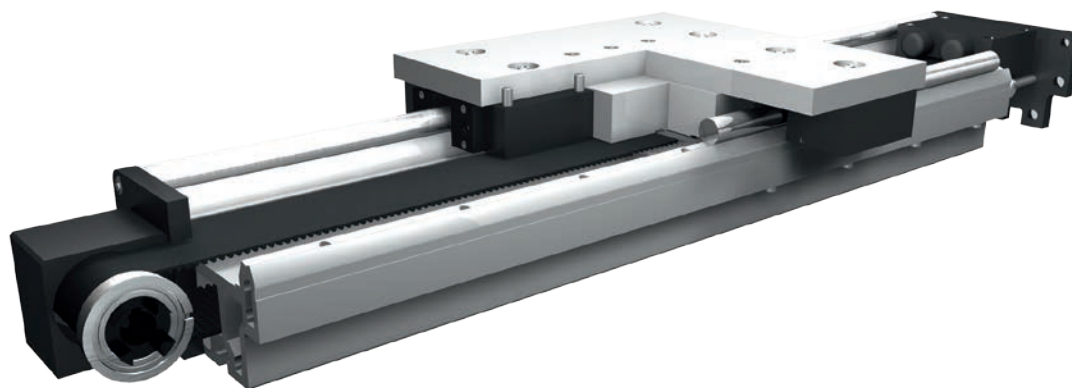

Function:

This unit consists of an aluminium profile with hardened steel guide rods mounted on top of the profile. The carriage, which has internal linear ball bearings that can be adjusted free of play, is driven along the guide rods by a timing belt. The pulleys have maintenance-free ball bearings. Opposite the driven side there is an integrated timing-belt tensioner which can be readjusted by 2 screws.

Fitting position:

As required. Max. length 6.400 mm without joints.

Carriage mounting:

By tapped holes.

Unit mounting:

By T-slots and mounting sets. The linear axis can be combined with any T-slot profile.

Carriage support:

In the standard version, the carriage runs on 8 rollers which can be adjusted and serviced at a central servicing position. For longer carriages the number of rollers can be increased.

Repeatability ± 0,1.

Belt type:

HTD with steel reinforcement, no backlash when changing direction, repeatability: ± 0,1 mm.

Fores and torques

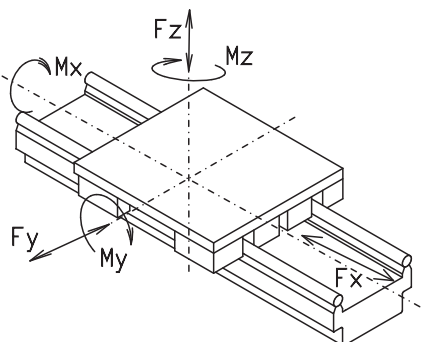

Size	ALLZ 203		ALLZ 204	
Forces/Torques	static	dynamic	static	dynamic
F_x (N)	-	5610	-	5610
F_y (N)	23000	18400	30000	24000
F_z (N)	11000	8800	16200	13000
M_x (Nm)	1180	950	1870	1500
M_y (Nm)	1870	1500	3000	2400
M_z (Nm)	3800	3100	5600	4500
All forces and torques related to the following:				
existing values $\frac{F_y}{F_{y_{dyn}}} + \frac{F_z}{F_{z_{dyn}}} + \frac{M_x}{M_{x_{dyn}}} + \frac{M_y}{M_{y_{dyn}}} + \frac{M_z}{M_{z_{dyn}}} \leq 1$				
table values $F_{y_{dyn}}, F_{z_{dyn}}, M_{x_{dyn}}, M_{y_{dyn}}, M_{z_{dyn}}$				
No-load torque				
Nm	4		4	
Speed				
(m/s) max	8		8	
Geometrical moments of inertia of aluminium profile				
I_x mm ⁴	2,26 x 10 ⁷		2,98 x 10 ⁷	
I_y mm ⁴	8,75 x 10 ⁷		10,22 x 10 ⁷	
Elastic modulus N/mm ²	70000		70000	

10.1

Formula: ALLZ

Driving torque:

$$M_o = \frac{F \cdot P \cdot S_1}{2000 \cdot \pi} + M_{leer}$$

$$P_o = \frac{M_o \cdot n}{9550}$$

- F = force (N)
- P = pulley action perimeter (mm)
- S₁ = safety factor 1,2 ... 2
- M_{leer} = no-load torque (Nm)
- n = rpm pulley (min⁻¹)
- M_o = driving torque (Nm)
- P_o = motor power (KW)

$$f = \frac{F \cdot l^3}{E \cdot I \cdot 192}$$

- f = deflection (mm)
- F = load (N)
- l = free length (mm)
- E = elastic modulus 70000 (N/mm²)
- I = second moment of area (mm⁴)

Positioning system ALLZ 203, 204

Dimensions (mm)

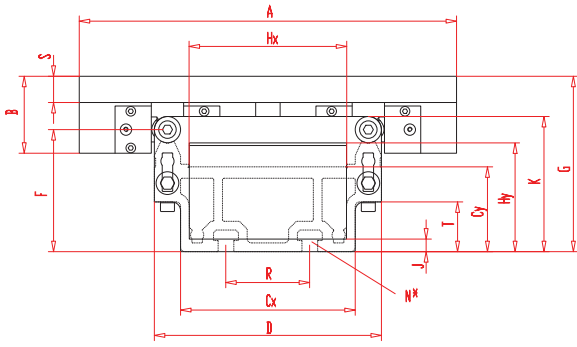

Increasing the carriage length will increase the basic length by the same amount.

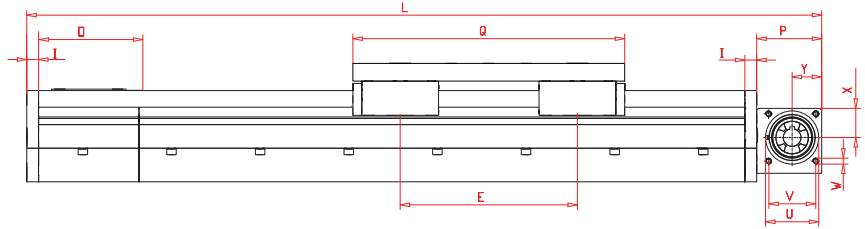
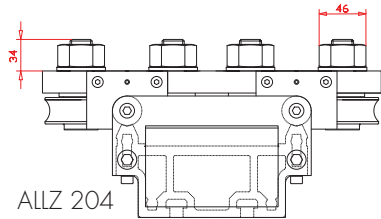
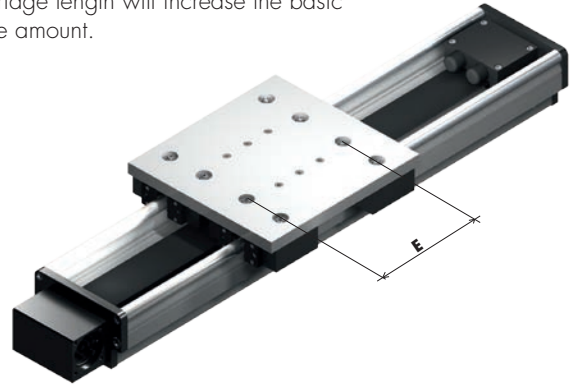

Size	Basic length L	A	B	Cx	Cy	D	E	F	G	Hx	Hy	I	J	K	N for	O	P	Q	R	S	T	U	V	W	X	Y	Basic weight	Weight per 100 mm
ALLZ 203	792	432	88	200	97	260	300	140	200,5	180,5	124,5	20	14,5	154,5	M16	182	110	460	96	30	57	90	80	10	49,5	50	90 kg	4,0 kg
ALLZ 204	822	460	80	200	97	270	355	145	199	180,5	124,5	20	14,5	165	M16	182	110	490	96	30	57	90	80	10	49,5	50	92 kg	4,9 kg

3 Guide rod size:
(3) Ø=30 (4) Ø=40

0 Choice of guide body profile:
(0) Standard (2) corrosion-protected guide rods and screws
(4) expanded corrosion-protected version (depending on the availability of components)

0 Drive version:

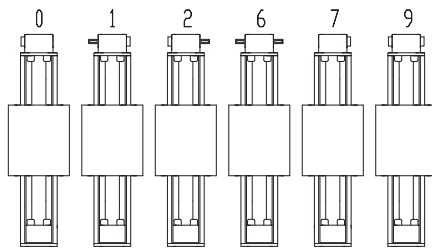

9 is as 0, but with coupling claws on both sides.

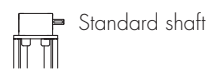
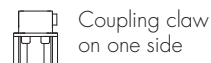

The standard version is supplied without shaft. A shaft can be retrofitted by inserting it into the pulley bore and securing it with 2 locking rings.

Belt table

Code No.	Belt	mm/rev.	Number of teeth
0 7	8M100	224	28

Shaft dimensions / Coupling claw

Size	Shaft ø h6 x length	Key	Coupling
203	30 x 55	8x7x50	24
204	30 x 55	8x7x50	24

Basic length + stroke = total length

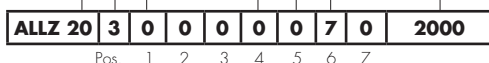

Sample ordering code:
ALLZ203, guide rods 30 mm, standard body profile, coupling claw on both side, toothed belt 8M100, 1208 mm stroke.

