

Positioning system ELFZ 60S, 80S, 100, 125

Specifications

3.1

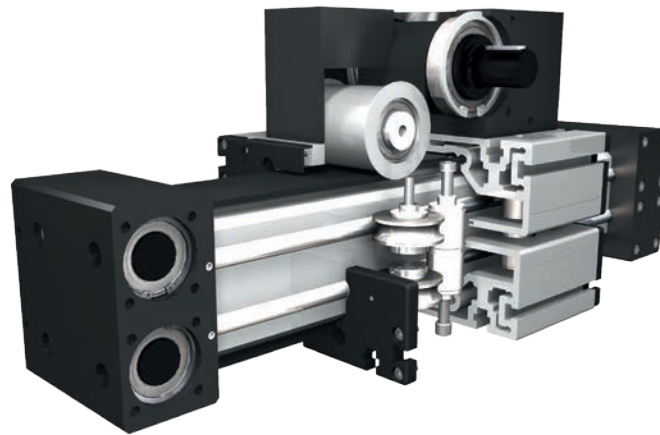

Function:

This special lifting unit consists of an aluminium square profile with hardened steel guide rods. The carriages, which have internal linear ball bearings that can be adjusted free of play, are driven along the guide rods by a timing belt. The rotating timing belt pulleys have maintenance-free ball bearings. One rotation of the drive pulley complies with 1/2 linear circumference of the drive pulley. Belt tension can be readjusted by a simple tensioning device in one of the carriages. This device can also be used for symmetrical adjustment of two or more linear units running parallel.

Fitting position:

As required. Max. length without joints 6.000 mm.

Carriage mounting:

By T-slots.

Unit mounting:

By T-slots or tapped holes in the bearing blocks, or mounting sets.

Belt type:

HTD with steel reinforcement, no backlash when changing direction, repeatability ± 0,1 mm.

Forces and torques

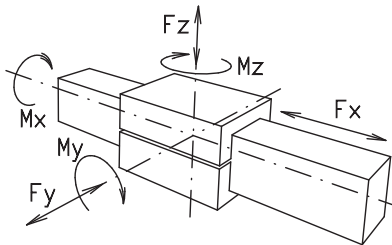

Size	ELFZ 60S		ELFZ 80S		ELFZ 100		ELFZ 125	
Forces/Torques	static	dynamic	static	dynamic	static	dynamic	static	dynamic
F_x (N)	3600	3200	6200	5400	8700	7600	12000	10400
F_y (N)	8200	6200	9200	7200	16000	13000	24000	18000
F_z (N)	4320	3200	6000	3600	7200	4400	12000	9000
M_x (Nm)	176	130	340	280	600	460	1200	900
M_y (Nm)	380	280	540	460	800	540	1500	1200
M_z (Nm)	460	340	600	440	1500	1000	2700	2300
All forces and torques relate to the following:								
existing values $\frac{F_y}{F_{y_{dyn}}} + \frac{F_z}{F_{z_{dyn}}} + \frac{M_x}{M_{x_{dyn}}} + \frac{M_y}{M_{y_{dyn}}} + \frac{M_z}{M_{z_{dyn}}} \leq 1$								
table values $\frac{F_y}{F_{y_{dyn}}} + \frac{F_z}{F_{z_{dyn}}} + \frac{M_x}{M_{x_{dyn}}} + \frac{M_y}{M_{y_{dyn}}} + \frac{M_z}{M_{z_{dyn}}} \leq 1$								
No-load torque								
Nm	1,3		1,5		2		2	
Speed								
(m/s) max	4		4		4		4	
Drive torque								
max (Nm)	48		120		386		500	
Geometrical moments of inertia of aluminium profile								
I_x mm ⁴	6,79x10 ⁵		1,89x10 ⁶		4,44x10 ⁶		10,15x10 ⁶	
I_y mm ⁴	6,9710 ⁵		1,8910 ⁶		4,48x10 ⁶		10,15x10 ⁶	
E-Modulus N/mm ²	70000		70000		70000		70000	

For life-time calculation of rollers use our CD-ROM or homepage!

Formula: ELFZ

Driving torque:

$$M_o = \frac{F \cdot p \cdot S}{2000 \cdot \pi \cdot 2} + M_{leer}$$

$$P_o = \frac{M_o \cdot n}{9550}$$

- F = force (N)
- P = pulley action perimeter (mm)
- S = safety factor 1,2 ... 2
- M_{leer} = no-load torque (Nm)
- n = rpm pulley (min⁻¹)
- M_o = driving torque (Nm)
- P_o = motor power (KW)

$$f = \frac{F \cdot L^3}{E \cdot I \cdot 192}$$

- f = deflection (mm)
- F = load (N)
- L = free length (mm)
- E = elastic modulus 70000 (N/mm²)
- I = second moment of area (mm⁴)

Positioning system ELFZ 60S, 80S, 100, 125

Dimensions (mm)

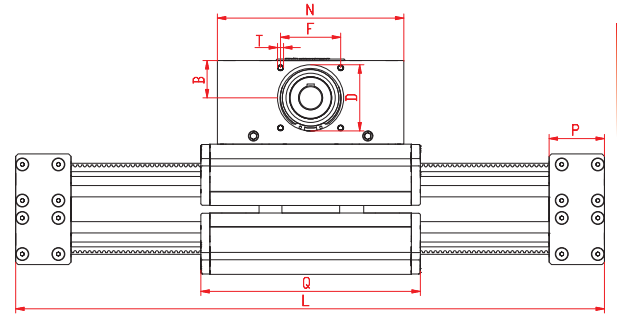
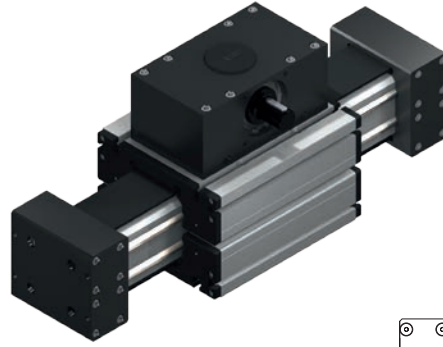
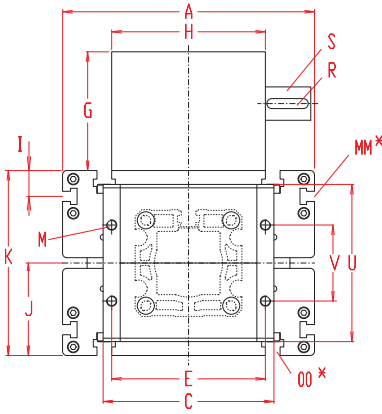

Increasing the carriage length will increase the basic length by the same amount.

*For slide nuts refer to chapter 2.2 page 2

Size	Basic length L	A	B	C	D	E	F	G	H	I	J	K	MM for	M	N	OO for	P	Q	R	S	T	U	V	Basic weight	Weight per 100 mm
ELFZ 60S	410	170	38	108	68	97	60	102	100	-	53	106	-	M8	180	M8	97	214	6x6x40	18x45	M8	97	60	23,1 kg	0,64 kg
ELFZ 80S	580	190	60	126	90	106	80	139	130	12,5	71	142	M6	M10	270	M 8	130	315	8x7x40	30x45	M10	130	70	51 kg	1,20 kg
ELFZ 100	530	230	62	170	110	150	100	143	160	29	89	178	M10	M10	310	M10	77	365	12x8x50	40x55	M10	150	80	69 kg	1,80 kg
ELFZ 125	560	295	62	200	110	180	100	139	180	30	107,5	218	M10	M12	310	M12	92	365	12x8x50	40x55	M10	186	89	87,5 kg	2,70 kg

0 Choice of guide body profile:

- (0) Standard (2) corrosion-protected guide rods and screws
- (4) expanded corrosion-protected version (depending on the availability of components)

0 Choice of carriages:



Size	Version 1	
	Q	L
60S	380	580
80S	489	750
100	575	740
125	640	830

1 Drive version:

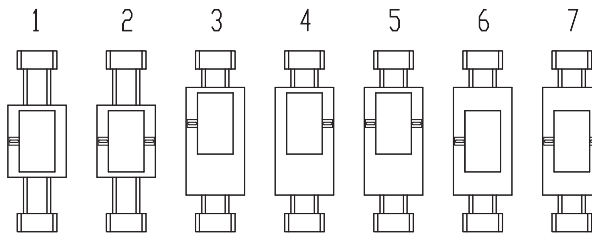

Belt table

Code No.	Size	Belt	mm/rev. ≈ linear	Number of teeth
0 3	60S	8M30	192 ≈ 96	24
0 4	80S	8M50	256 ≈ 128	32
0 7	100	8M70	304 ≈ 152	38
0 9	125	8M100	304 ≈ 152	38

Shaft dimensions

Size	Shaft ø h6 x length	Key
60S	18 x 45	6x6x40
80S	30 x 45	8x7x40
100	40 x 55	12x8x50
125	40 x 55	12x8x50

Basic length + stroke = total length

ELFZ 125 0 0 0 1 0 9 1 01500

Pos. 1 2 3 4 5 6 7

For combination kits and connecting elements refer to chapter 2.2

Sample ordering code:

ELFZ 125 with standard body profile, standard carriage, shaft Pos. 1, 940 mm stroke