

Positioning system ELFZ 60S, 80S, 100, 125

Specifications

ATEX 95
 **II 2G c IIB T4**
 **II 3D T125°C**

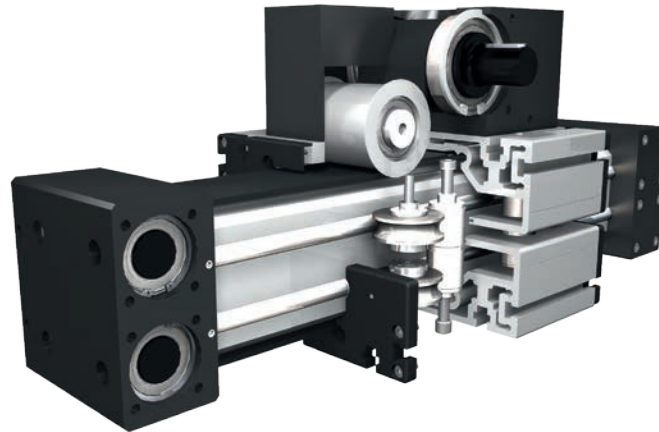

3.1

Function:

Like ELFZ. The positioning system is suitable for use according to the intended purpose in potentially explosive areas (see ATEX 95 marking). An operating manual is included in the scope of delivery. The system is certified for the following areas:

ATEX 95 II 2G EEx c IIB T4:

All application areas except for underground mining. Gas atmosphere category 2, explosion protection category: protection due to secure construction (design security). Equipment group IIB. Temperature class T4=135°C

ATEX 95 II 3D T125°C:

All application areas except for underground mining. Dust atmosphere category 3. Maximum permissible surface temperature: 125°C.

Fitting position:

As required. Max. length without joints 3.000 mm.

Carriage mounting:

By T-slots.

Unit mounting:

By T-slots or tapped holes in the bearing blocks, or mounting sets.

Belt type:

HTD with steel reinforcement, no backlash when changing direction, repeatability ± 0,1 mm.

Forces and torques

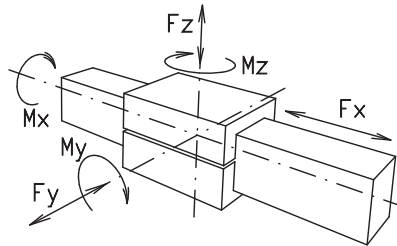

Size	ELFZex 60S		ELFZex 80S		ELFZex 100		ELFZex 125		
	Forces/Torques		static	dynamic	static	dynamic	static	dynamic	static
F_x (N)	1800	1550	3000	2600	4200	3650	6000	5200	
F_y (N)	3820	3056	4438	3550	6200	4960	9960	7968	
F_z (N)	1870	1496	1052	842	1292	1043	2190	1752	
M_x (Nm)	104	82	134	108	202	162	440	352	
M_y (Nm)	132	106	154	140	272	218	560	448	
M_z (Nm)	274	220	364	292	652	520	1272	1018	
All forces and torques relate to the following:									
existing values $\frac{F_y}{F_{y_{dyn}}} + \frac{F_z}{F_{z_{dyn}}} + \frac{M_x}{M_{x_{dyn}}} + \frac{M_y}{M_{y_{dyn}}} + \frac{M_z}{M_{z_{dyn}}} \leq 1$									
table values									
No-load torque									
Nm	1,2		1,5		2		2		
Speed									
(m/s) max	1		1		1		1		
Drive torque									
max (Nm)	27		62		101		145		
Geometrical moments of inertia of aluminium profile									
I_x mm ⁴	6,79x10 ⁵		1,89x10 ⁶		4,44x10 ⁶		10,15x10 ⁶		
I_y mm ⁴	6,97x10 ⁵		1,89x10 ⁶		4,48x10 ⁶		10,15x10 ⁶		
E-Modulus N/mm ²	70000		70000		70000		70000		

For life-time calculation of rollers use our CD-ROM or homepage!

Formula: ELFZ

Driving torque:

$$M_o = \frac{F \cdot P \cdot S}{2000 \cdot \pi \cdot 2} + M_{leer}$$

$$P_o = \frac{M_o \cdot n}{9550}$$

- F = force (N)
- P = pulley action perimeter (mm)
- S = safety factor 1,2 ... 2
- M_{leer} = no-load torque (Nm)
- n = rpm pulley (min⁻¹)
- M_o = driving torque (Nm)
- P_o = motor power (KW)

$$f = \frac{F \cdot L^3}{E \cdot I \cdot 192}$$

- f = deflection (mm)
- F = load (N)
- L = free length (mm)
- E = elastic modulus 70000 (N/mm²)
- I = second moment of area (mm⁴)

Positioning system ELFZ 60S, 80S, 100, 125

Dimensions (mm)

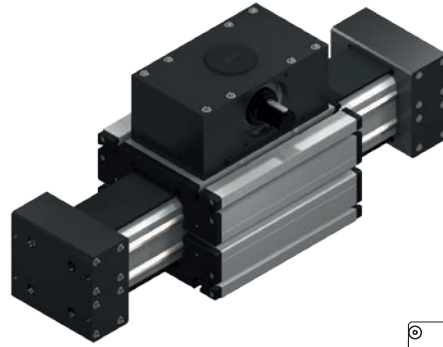
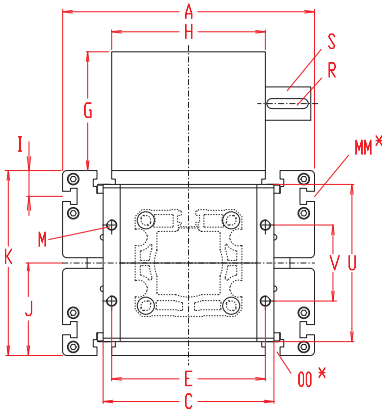

ATEX 95
 II 2G c IIB T4
 II 3D T125°C

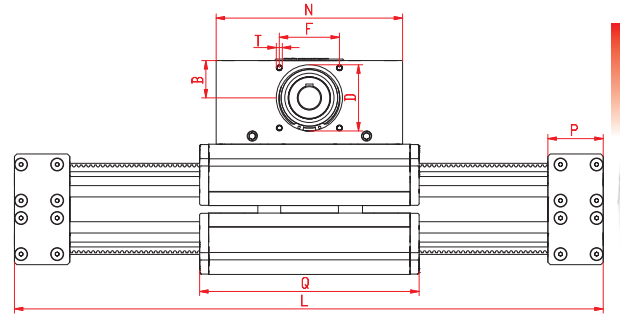

Increasing the carriage length will increase the basic length by the same amount.

*For slide nuts refer to chapter 2.2 page 2

Size	Basic length L	A	B	C	D	E	F	G	H	I	J	K	MM for	M	N	OO for	P	Q	R	S	T	U	V	Basic weight	Weight per 100 mm
ELFZex 60S	430	170	38	108	68	97	60	102	100	-	53	106	-	M8	180	M8	97	214	6x6x40	18x45	M8	97	60	23,2 kg	0,64 kg
ELFZex 80S	600	190	60	126	90	106	80	139	130	12,5	71	142	M6	M10	270	M8	130	315	8x7x40	30x45	M10	130	70	51 kg	1,20 kg
ELFZex 100	560	230	62	170	110	150	100	143	160	29	89	178	M10	M10	310	M10	77	365	12x8x50	40x55	M10	150	80	69 kg	1,80 kg
ELFZex 125	590	295	62	200	110	180	100	139	180	30	107,5	218	M10	M12	310	M12	92	365	12x8x50	40x55	M10	186	89	87,5 kg	2,70 kg

0 Choice of guide body profile:

- (0) Standard (2) corrosion-protected guide rods and screws
- (4) expanded corrosion-protected version (depending on the availability of components)

0 Choice of carriages:



Size	Version 1	
	Q	L
60S	380	600
80S	489	770
100	575	770
125	640	860

1 Drive version:

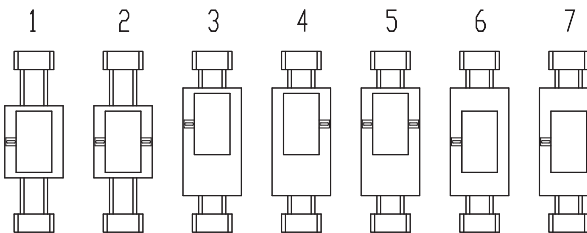

Belt table

Code No.	Size	Belt	mm/rev. ≈ linear	Number of teeth
0 3	60S	8M30	192 ≈ 96	24
0 4	80S	8M50	256 ≈ 128	32
0 7	100	8M70	304 ≈ 152	38
0 9	125	8M100	304 ≈ 152	38

Shaft dimensions

Size	Shaft ø h6 x length	Key
60S	18 x 45	6x6x40
80S	30 x 45	8x7x40
100	40 x 55	12x8x50
125	40 x 55	12x8x50

Basic length + stroke = total length

ELFZex 125 0 0 0 1 0 9 1 01500

Pos. 1 2 3 4 5 6 7

For combination kits and connecting elements refer to chapter 2.2

Sample ordering code:

ELFZ 125 with standard body profile, standard carriage, shaft Pos. 1, 910 mm stroke