

Positioning system ELHZ 60, 60S, 80, 80S, 100, 125

Internal belt drive

Specifications

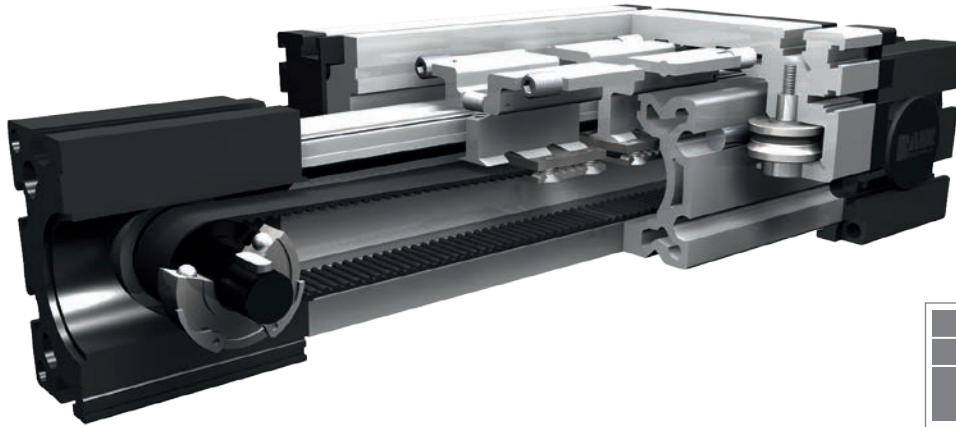

3.1

Function:

This linear unit consists of an aluminium square profile with integrated, hardened steel guide rods. The carriage, which has internal linear ball bearings that can be adjusted free of play, is driven along the guide rods by a timing belt. Toothed pulley has maintenance-free ball bearings. Belt tension can be readjusted by a simple screw adjustment device in the carriage. This device can also be used for symmetrical adjustment of two or more linear units running parallel.

This linear unit is suitable for application in clean rooms of clean-room classification 1.000 (corresponding to US Fed. Standard 209 E).

Fitting position: As required. Max. length 3.000 mm without joints.

Carriage mounting: By T-slots.

Unit mounting: By tapped holes or tapped holes in the bearing block, mounting sets.

Belt type: HTD with steel reinforcement, no backlash when changing direction, repeatability ± 0,1 mm.

Forces and torques	Size	ELHZ 60		ELHZ 60 S		ELHZ 80		ELHZ 80 S		ELHZ 100		ELHZ 125	
	Forces/Torques	static	dynamic	static	dynamic	static	dynamic	static	dynamic	static	dynamic	static	dynamic
	F _x (N)	700	580	700	580	1000	840	1000	840	3100	2600	5000	4950
	F _y (N)	3000	2000	4100	3100	3000	2000	4600	3600	8000	6500	12000	9000
	F _z (N)	1700	1100	2160	1600	1700	1100	3000	1800	3600	2200	6000	4500
	M _x (Nm)	67	43	88	65	90	55	170	140	300	230	600	450
	M _y (Nm)	90	70	190	140	110	80	270	230	400	270	750	600
	M _z (Nm)	120	100	230	170	150	120	300	220	750	500	1350	1150
All forces and torques relate to the following: existing values $\frac{F_y}{F_{y_{dyn}}} + \frac{F_z}{F_{z_{dyn}}} + \frac{M_x}{M_{x_{dyn}}} + \frac{M_y}{M_{y_{dyn}}} + \frac{M_z}{M_{z_{dyn}}} \leq 1$ table values													
No-load torque													
Nm		0,5		0,5		0,8		1,2		1,2		1,6	
Speed													
(m/s) max		3		4		4		4		5		6	
Tensile force													
permanent (N)		700		700		1000		1000		3100		5000	
0,2 s (N)		800		800		1150		1150		3400		5450	
Geometrical moments of inertia of aluminium profile													
I _x mm ⁴		6,79x10 ⁵		6,79x10 ⁵		18,99x10 ⁵		18,99x10 ⁵		44,4x10 ⁵		101,5x10 ⁵	
I _y mm ⁴		6,97x10 ⁵		6,97x10 ⁵		18,97x10 ⁵		18,97x10 ⁵		44,8x10 ⁵		101,5x10 ⁵	
E-Modulus N/mm ²		70000		70000		70000		70000		70000		70000	

For life-time calculation of rollers use our CD-ROM or homepage!

Formula: ELHZ

Driving torque:

$$M_o = \frac{F \cdot P \cdot S_1}{2000 \cdot \pi} + M_{leer}$$

$$P_o = \frac{M_o \cdot n}{9550}$$

- F = force (N)
- P = pulley action perimeter (mm)
- S₁ = safety factor 1,2 ... 2
- M_{leer} = no-load torque (Nm)
- n = rpm pulley (min⁻¹)
- M_o = driving torque (Nm)
- P_o = motor power (KW)

$$f = \frac{F \cdot L^3}{E \cdot I \cdot 192}$$

- f = deflection (mm)
- F = load (N)
- L = free length (mm)
- E = elastic modulus 70000 (N/mm²)
- I = second moment of area (mm⁴)



Positioning system ELHZ 60, 60S, 80, 80S, 100, 125

Dimensions (mm)

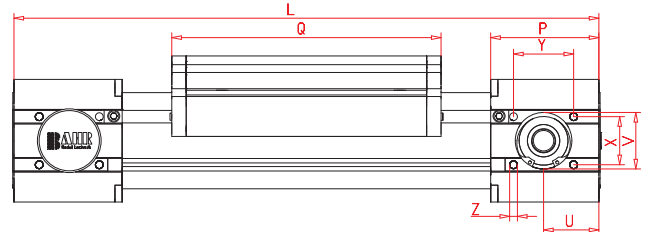
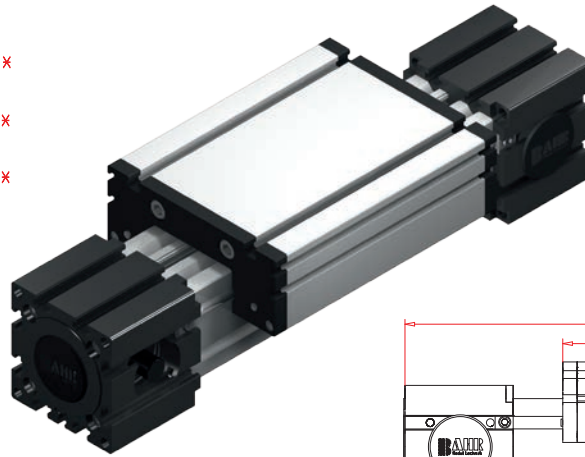
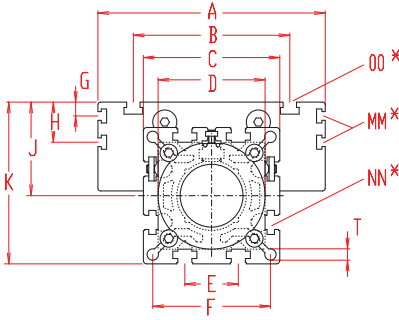

Increasing the carriage length will increase the basic length by the same amount.

*For slide nuts refer to chapter 2.2 page 2

Size	Basic length L	A	B	C	D	E	F	G	H	J	K	MM for	NN for	OO for	P	Q	T	U	V	W'	X	Y	Z	Basic weight	Weight per 100 mm
ELHZ 60	290	144	96	82	62x1	30	69	-	-	49	90	-	M 8	M 8	59	168	8,5	23	37	14	30	36	M 6	4,8 kg	0,62 kg
ELHZ 60S	315	170	108	82	62x1	30	69	-	-	53	94	-	M 8	M 8	59	194	8,5	23	37	14	30	36	M 6	5,8 kg	0,62 kg
ELHZ 80	375	170	117	102	80x1	40	88	10	30	70	121	M 6	M10	M10	90	194	8,5	38	47	18	40	50	M 8	10,0 kg	1,00 kg
ELHZ 80S	395	190	126	102	80x1	40	88	12,5	30	71	122	M 6	M10	M 8	90	214	8,5	38	47	18	40	50	M 8	11,0 kg	1,00 kg
ELHZ 100	530	230	155	130	110x1	50	112	-	29	89	154	M10	M10	M10	110	300	10,5	45	68	19	50	64	M10	24,0 kg	1,60 kg
ELHZ 125	630	295	200	165	130x2	60	142	-	30	107,5	190	M10	M10	M12	132	365	13,0	58	90	35	60	85	M10	37,0 kg	2,10 kg

W' = standard shaft

0 Choice of guide body profile:

- (0) Standard (2) corrosion-protected guide rods and screws
- (4) expanded corrosion-protected version (depending on the availability of components)

0 Choice of carriages:



Size	Version 1	
	Q	L
60	184	306
60S	214	336
80	210	391
80S	234	415
100	316	546
125	389	649

0 Drive version:

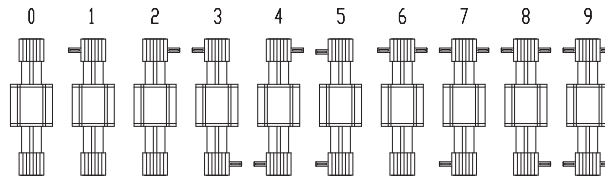

The standard version 0 is supplied with 4 flush mounted shafts.

Belt table

Code No.	Size	Belt	mm/rev.	Number of teeth
0 4	60 (S)	5M 25	80	16
0 4	80 (S)	5M 25	110	22
0 9	100	8M 48	144	18
0 9	125	8M 50	192	24

Shaft dimensions

Size	Shaft \varnothing h6 x length	Key
60 (S)	14 x 35	5x5x28
80 (S)	18 x 45	6x6x40
100	22 x 45	6x6x40
125	30 x 55	8x7x50

Basic length + stroke = total length

ELHZ 60 0 0 0 0 0 4 1 01500

Pos. 1 2 3 4 5 6 7

For combination kits and connecting elements refer to chapter 2.2

Sample ordering code:

ELHZ 60, with standard body profile, standard carriage and 4 flush mounted shafts, 1210 mm stroke.

