

Positioning system QLZE 60, 80, 100

Belt drive

Specifications

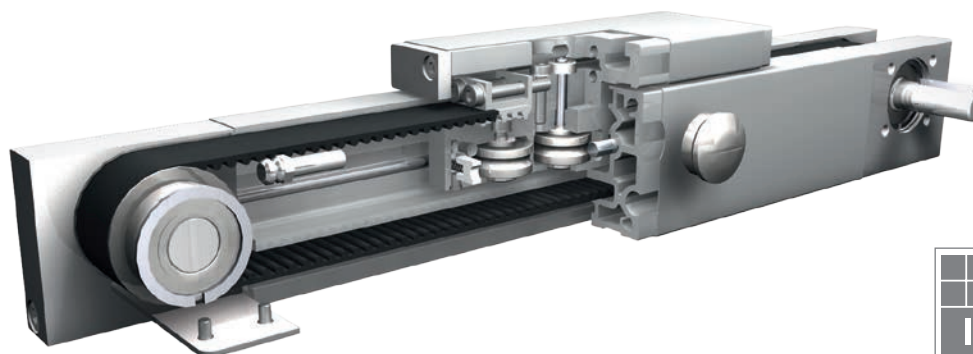

Function:

This unit consists of a square aluminium profile with an integrated roller guide and is covered by a stainless steel sheet (thickness 0.37mm, material 1.4301). The carriage is driven by a timing belt. Belt tension can be readjusted by a simple screw adjustment device in the carriage. This device can also be used for symmetrical adjustment of two or more linear units running parallel. This linear unit is based on the QLZ and is suitable for application in clean rooms of clean-room classification 1000 (corresponding to US Fed. Standard 209 E).

- Fitting position:** As required. Max. length 3.000 mm without joints.
- Carriage mounting:** By T-nuts and bores through the cover.
- Unit mounting:** By T-nuts and bores through the cover.
- Belt performance:** HTD with kevlar reinforcement, no backlash when changing direction, repeatability ± 0,1 mm.
- Carriage support:** In the standard version, the carriage runs on 4 rollers which can be adjusted and serviced at a central servicing position. For longer carriages the number of rollers can be increased.

Forces and torques

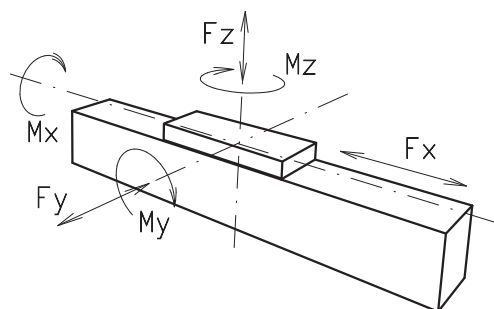

Size	60		80		100	
Forces/Torques	static	dynamic	static	dynamic	static	dynamic
F_x (N)	894	800	1900	1800	4000	3800
F_y (N)	399	333	1065	825	1267	1000
F_z (N)	599	433	999	799	1400	1133
M_x (Nm)	10	7	33	26	128	40
M_y (Nm)	40	33	66	53	93	73
M_z (Nm)	26	20	50	40	73	60
All forces and torques related to the following:						
existing values $\frac{F_y}{F_{y_{dyn}}} + \frac{F_z}{F_{z_{dyn}}} + \frac{M_x}{M_{x_{dyn}}} + \frac{M_y}{M_{y_{dyn}}} + \frac{M_z}{M_{z_{dyn}}} \leq 1$						
table values $\frac{F_y}{F_{y_{dyn}}} + \frac{F_z}{F_{z_{dyn}}} + \frac{M_x}{M_{x_{dyn}}} + \frac{M_y}{M_{y_{dyn}}} + \frac{M_z}{M_{z_{dyn}}} \leq 1$						
No-load torque						
Nm	1,0		1,3		2,0	
Speed						
(m/s) max	4		6		7	
Tensile force						
permanent (N)	900		1900		4000	
0,2 s (N)	1000		2090		4300	
Geometrical moments of inertia of aluminium profile						
I_x mm ⁴	4,3x10 ⁵		16,5x10 ⁵		43,0x10 ⁵	
I_y mm ⁴	4,8x10 ⁵		18,7x10 ⁵		48,8x10 ⁵	
Elastic modulus N/mm ²	70000		70000		70000	

For life-time calculation of rollers use our CD-ROM or homepage!

Formula: QLZE

Driving torque:

$$M_a = \frac{F \cdot P \cdot S_s}{2000 \cdot \pi} + M_{leer}$$

$$P_o = \frac{M_a \cdot n}{9550}$$

- F = force (N)
- P = pulley action perimeter (mm)
- S_s = safety factor 1,2 ... 2
- M_{leer} = no-load torque (Nm)
- n = rpm pulley (min⁻¹)
- M_a = driving torque (Nm)
- P_o = motor power (KW)

$$f = \frac{F \cdot L^3}{E \cdot I \cdot 192}$$

- f = deflection (mm)
- F = load (N)
- L = free length (mm)
- E = elastic modulus 70000 (N/mm²)
- I = second moment of area (mm⁴)

Positioning system QLZE 60, 80, 100

Dimensions (mm)

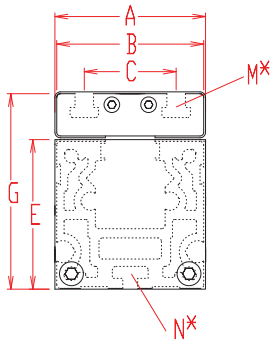

Increasing the carriage length will increase the basic length by the same amount.

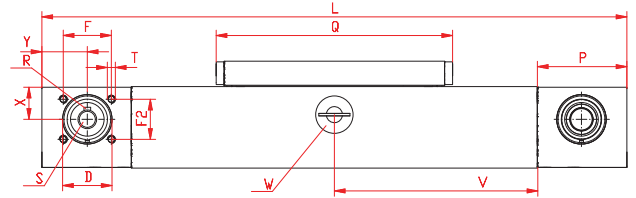
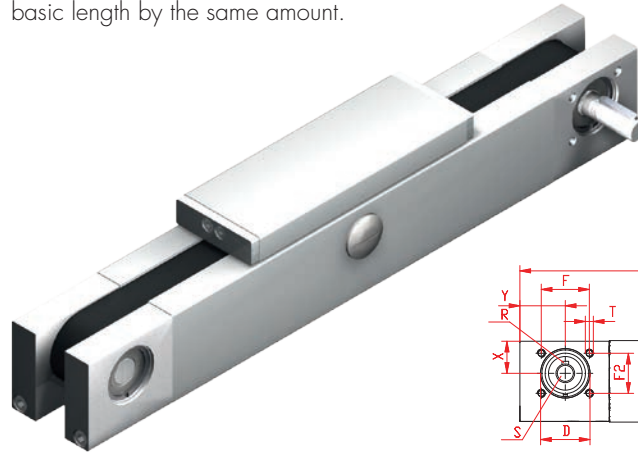

*For slide nuts refer to chapter 2.2 page 2

$V = Q + 100 \text{ mm}$ $W = \text{servicing position}$

Size	Basic length L	A	B	C	D	E	F/F2	G	N for	M for	P	Q	T	X	Y	Basic weight	Weight per 100 mm
QLZE 60	296	61	60	36	37	61	36/30	80	M 5	M 6	67	152	M 6	24,5	34	4,2 kg	0,48 kg
QLZE 80	400	81	80	50	55	81	50/50	107	M 6	M 8	95	196	M 8	32,5	47	10,6 kg	0,98 kg
QLZE 100	484	101	100	66	62	101	62/58	130	M 10	M 10	107	260	M 10	40	54	18,3 kg	1,37 kg

0 Choice of guide body profile:
 (0) Version with corrosion-protected components

0 Choice of carriages:

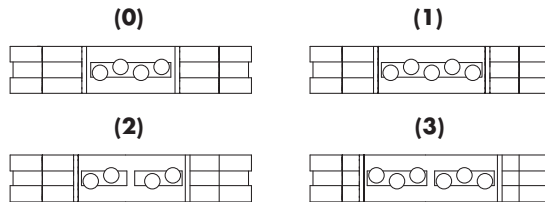

Size	Version 0		Version 1		Version 2		Version 3	
	Q	L	Q	L	Q	L	Q	L
60	152	296	192	336	232	376	232	376
80	196	400	246	450	296	500	296	500
100	260	484	320	544	388	604	388	604

2 Drive version:

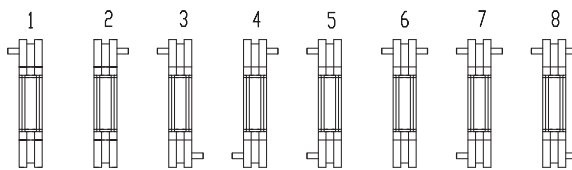

The standard version is supplied shaft pos. 2

Size	Shaft	
	R Key	S ø h6 x length
60	5x5x28	14 x 35
80	6x6x40	18 x 45
100	6x6x40	22 x 45

Belt table

Code No.	Size	Belt	Pulley	
			mm/rev.	Number of teeth
0 3	60	5M25	130	26
0 4	80	8M30	176	22
0 7	100	8M50	224	28

Basic length + stroke = total length

QLZE 80 1 0 0 2 0 4 1 01500

Pos. 1 2 3 4 5 6 7

Sample ordering code:

QLZE80, standard body profile, standard carriage, shaft pos.2, 1100 mm stroke

For additional accessories refer to main catalogue chapter 2.2 – 3.2

11.1

