

Positioning system QST/KE 60, 80, 100

Spindle drives

Specifications

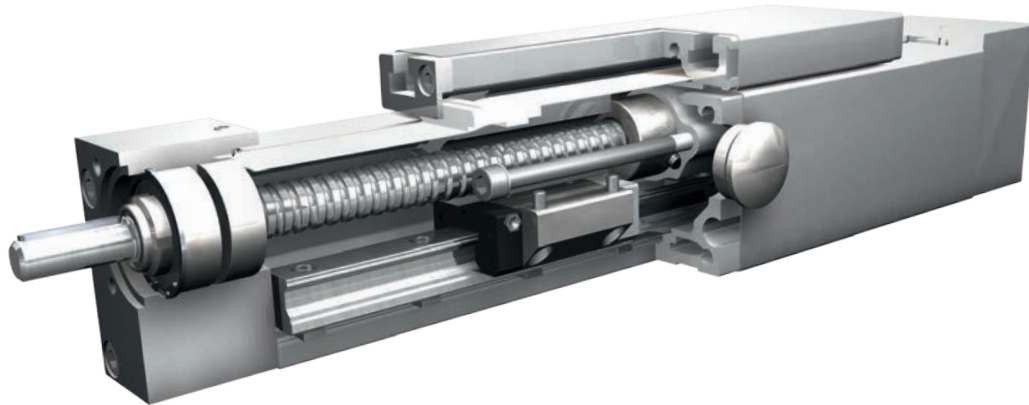

Function:

This unit consists of a square aluminium profile with an integrated ball rail and is covered by a stainless steel sheet (thickness 0.37mm, material 1.4301). The carriage is driven by means of a rotating spindle with leading nut. The openings of the guide body are sealed by a stainless steel cover band to protect the drive from splash water and dust.

Fitting position:

As required, max. length 3000mm

Carriage connection:

By T-nuts and bores through the cover.

Unit mounting:

By the bearing blocks

Forces and torques

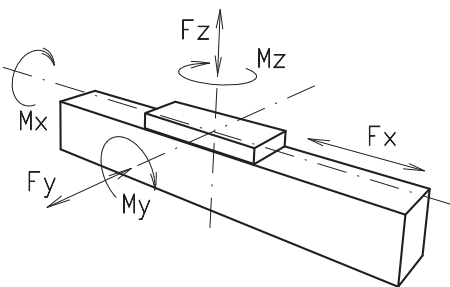

Size	QST/KE 60		QST/KE 80		QST/KE 100	
permitted dyn. Forces*	5000 km	10000 km	5000 km	10000 km	5000 km	10000 km
F _x (N)	900	800	2500	2000	5000	4000
F _y (N)	1415	1010	3570	2542	4082	2910
F _z (N)	3525	2510	8500	6050	10300	7360
M _x (Nm)	33	23	107	76	142	101
M _y (Nm)	190	143	604	430	838	597
M _z (Nm)	176	125	550	392	745	532
All forces and torques related to the following:						
existing values $\frac{F_y}{F_{y_{dyn}}} + \frac{F_z}{F_{z_{dyn}}} + \frac{M_x}{M_{x_{dyn}}} + \frac{M_y}{M_{y_{dyn}}} + \frac{M_z}{M_{z_{dyn}}} \leq 1$						
table values						
No-load torque						
Trapezoidal	18x4/18x8		24x5/24x10		32x6/32x12	
Nm	0,8/0,9		0,8/1,0		2,0/2,2	
Ball screw	16x5/16x10		25x5/20x20/25x10		32x5/32x10	
Nm	0,5/0,8		0,5/0,9/0,8		1,7/2,1	
Geometrical moments of inertia of aluminium profile						
I _x mm ⁴	4,3x10 ⁵		14,0x10 ⁵		43,0x10 ⁵	
I _y mm ⁴	4,8x10 ⁵		16,6x10 ⁵		48,8x10 ⁵	
E-Modulus N/mm ²	70000		70000		70000	

* referred to lifetime

Formula: QST/KE

Driving torque:

$$M_o = \frac{F \cdot P \cdot S_i}{2000 \cdot \pi \cdot \mu} + M_{leer}$$

$$P_o = \frac{M_o \cdot n}{9550}$$

- F = force (N)
- P = thread pitch (mm)
- S_i = safety factor 1,2 ... 2
- M_{leer} = no-load torque (Nm)
- n = rpm of screw (min⁻¹)
- M_o = driving torque (Nm)
- μ = screw efficiency
- P_o = motor power (KW)

Efficiency of lead screws:

- All ballscrew 0.900
- Tr 18x4 0,399
- Tr 18x8 0,565
- Tr 24x5 0,384
- Tr 24x10 0,550
- Tr 32x6 0,360
- Tr 32x12 0,524

$$f = \frac{F \cdot L^3}{E \cdot I \cdot 192}$$

- f = deflection (mm)
- F = load (N)
- L = free length (mm)
- E = elastic modulus 70000 (N/mm²)
- I = second moment of area (mm⁴)

For the diagram for critical speeds of lead screws refer to the main catalog chapter 4.2 page 3

Positioning system QST/KE 60, 80, 100

Dimensions (mm)

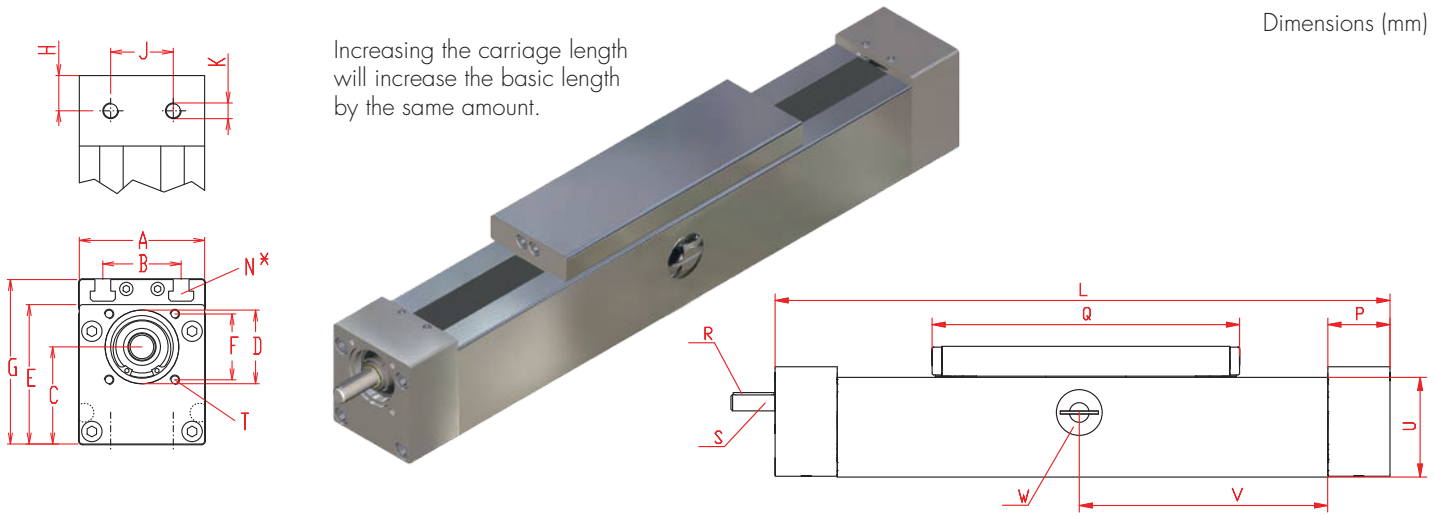

*For slide nuts refer to chapter 2.2 page 2

$V = Q + 100 \text{ mm}$

W = servicing position

Size □	Basic length L	A	B	C	D	E	F □	G	H	J	K for	N for	P	Q	Shaft		T for	U	Basic weight	Weight per 100 mm
															R Key	S Øh6 x length				
QST/KE 60	270	61	36	45,5	37	67,5	32	80	19	18	M6	M6	38	188	3x3x25	10h6x27	M5	61	4,1 kg	0,5 kg
QST/KE 80	350	81	50	62,5	47	89,5	42	107	22,5	40	M10	M8	45	250	5x5x28	14h6x35	M6	81	7,5 kg	0,9 kg
QST/KE 100	410	101	66	75,5	68	112,5	60	130	28,5	50	M10	M10	57	288	6x6x40	22h6x45	M8	101	14,8 kg	1,3 kg

K Spindle:

(T) Trapezoidal thread (K) Ballscrew

1 Selection of screw:

(1) right hand (Standard) (2) left hand (Ballscrew by inquiry)

0 Choice of guide body profile:

(0) Version with corrosion-protected components
(1) Version 0 but with not corrosion-protected guidings

0 Choice of carriage:



Size	Carriage version 1	
	Q	Basic length L
60	255	350
80	336	436
100	383	510

0 Drive version:

(0) one shaft (locating bearing side) (1) one shaft (non-locating bearing side) (2) shaft on both sides

0 Selection of screw:

Size	Standard	Multistart screw	Standard	Multistart screw
	trapezoidal thread standard		ballscrew standard	
60	(0) Tr 18x4	(1) Tr 18x8	(0) Kg 16x5	(1) Kg 16x10 (2) Kg 16x16
80	(0) Tr 24x5	(1) Tr 24x10	(0) Kg 25x5	(1) Kg 20x20 (2) Kg 25x10
100	(0) Tr 32x6	(1) Tr 32x12	(0) Kg 32x5	(1) Kg 32x10 (2) Kg 32x32 *
	trapezoidal thread stainless		ballscrew stainless by inquiry	
60	(4) Tr 18x4	(5) Tr 18x8		
80	(4) Tr 24x5	(5) Tr 24x10		
100	(4) Tr 32x6	(5) Tr 32x12		

* Basic and carriage length (L and Q) increase by 47 mm

0 Ballscrew pitch accuracy:

(0) 0,1 mm / 300 mm (Standard) (1) 0,05 mm / 300 mm (2) 0,025 mm / 300 mm

0 End play of ball nut:

(0) 0,04 mm (Standard) (1)** < 0,02 mm (2)** 2% apply prestress
** only in combination with **pitch accuracy (1) or (2)**

1500 Basic length + stroke = total length

Q S K E 80 1 0 0 0 0 0 0 0 1500
Pos. 1 2 3 4 5 6 7

Sample ordering code:

QSKE80, ballscrew right hand thread, full stainless version, standard carriage, one shaft (locating bearing side), spindle 25x5, 1150 mm stroke.

