

Positioning system QSIZE 60, 80, 100

Belt drive

Specifications

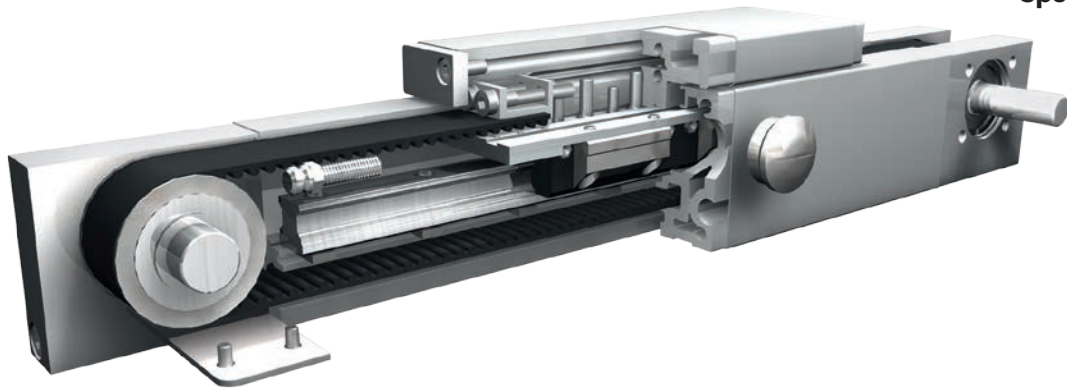

Function:

This unit consists of a square aluminium profile with an integrated ball rail guide and is covered by a stainless steel sheet (thickness 0.37mm, material 1.4301). The carriage is moved by a belt drive. Belt tension can be readjusted by a simple screw adjustment device in the carriage. This device can also be used for symmetrical adjustment of two or more linear units running parallel.

Fitting position:

As required. Max. length 3.000 mm without joints.

Carriage mounting:

By T-nuts and bores through the cover.

Unit mounting:

By T-nuts and bores through the cover.

Belt performance:

HTD with kevlar reinforcement, no backlash when changing direction, repeatability ± 0,1 mm.

Carriage support:

In the standard version, the carriage runs on two runner blocks which can be adjusted and serviced at a central servicing position. For longer carriages the number of runner blocks can be increased.

Forces and torques

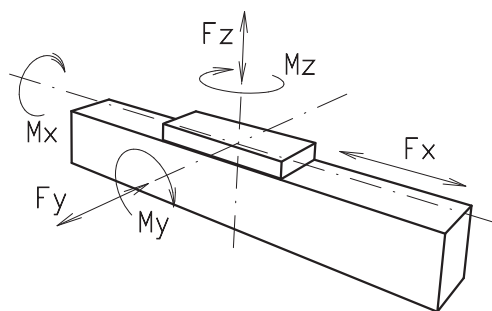

Size	60		80		100	
permitted dyn. Forces*	5000 km	10000 km	5000 km	10000 km	5000 km	10000 km
F _x (N)	894	800	1900	1800	4000	3800
F _y (N)	1410	990	3570	2550	4080	2900
F _z (N)	3520	2500	8500	6050	10300	7270
M _x (Nm)	33	23	107	75	142	101
M _y (Nm)	104	73	310	222	439	311
M _z (Nm)	100	70	296	210	412	292
C (N)	7800		18800		22800	
All forces and torques related to the following:						
existing values $\frac{F_y}{F_{y_{dyn}}} + \frac{F_z}{F_{z_{dyn}}} + \frac{M_x}{M_{x_{dyn}}} + \frac{M_y}{M_{y_{dyn}}} + \frac{M_z}{M_{z_{dyn}}} \leq 1$						
table values $\frac{F_y}{F_{y_{dyn}}} + \frac{F_z}{F_{z_{dyn}}} + \frac{M_x}{M_{x_{dyn}}} + \frac{M_y}{M_{y_{dyn}}} + \frac{M_z}{M_{z_{dyn}}} \leq 1$						
No-load torque						
Nm	1,3		1,8		2,3	
Speed						
(m/s) max	5		5		5	
Tensile force						
permanent (N)	900		1900		4000	
0,2 s (N)	1000		2090		4300	
Geometrical moments of inertia of aluminium profile						
I _x mm ⁴	4,3x10 ⁵		16,5x10 ⁵		43,0x10 ⁵	
I _y mm ⁴	4,8x10 ⁵		18,7x10 ⁵		48,8x10 ⁵	
Elastic modulus N/mm ²	70000		70000		70000	

* referred to lifetime

Formula: QSIZE

Driving torque:

$$M_o = \frac{F \cdot P \cdot S_s}{2000 \cdot \pi} + M_{leer}$$

$$P_o = \frac{M_o \cdot n}{9550}$$

- F = force (N)
- P = pulley action perimeter (mm)
- S_s = safety factor 1,2 ... 2
- M_{leer} = no-load torque (Nm)
- n = rpm pulley (min⁻¹)
- M_o = driving torque (Nm)
- P_o = motor power (KW)

Deflection:

$$f = \frac{F \cdot L^3}{E \cdot I \cdot 192}$$

- f = deflection (mm)
- F = load (N)
- L = free length (mm)
- E = elastic modulus 70000 (N/mm²)
- I = second moment of area (mm⁴)

Nominal lifetime:

$$L = \left(\frac{C}{F}\right)^3 \times 10^5$$

- L = Lifetime in meter
- C = Dynamic load factor (N)
- F = Middle load (N)

Positioning system QSIZE 60, 80, 100

Dimensions (mm)

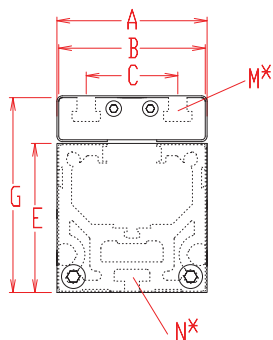

Increasing the carriage length will increase the basic length by the same amount.

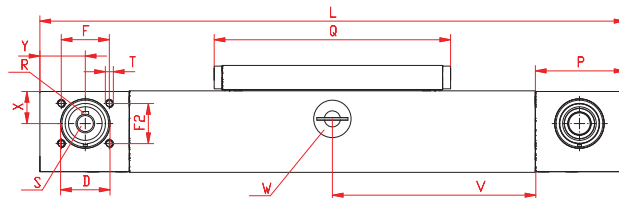
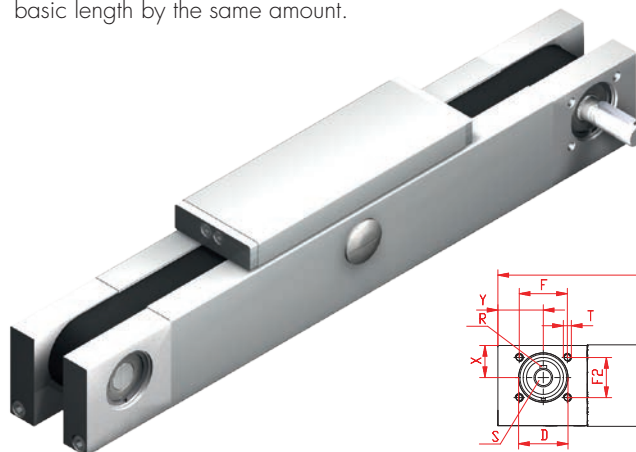

*For slide nuts refer to chapter 2.2 page 2

$V = Q + 100 \text{ mm}$ $W = \text{servicing position}$

Size	Basic length L	A	B	C	D	E	F/F2	G	N for	M for	P	Q	T	X	Y	Basic weight	Weight per 100 mm
QSIZE 60	316	61	60	36	37	61	36/30	80	M 5	M 6	67	177	M 6	24,5	34	4,2 Kg	0,64 kg
QSIZE 80	440	81	80	50	55	81	50/50	107	M 6	M 8	95	232	M 8	32,5	47	10,6 Kg	1,08 Kg
QSIZE 100	504	101	100	66	62	101	62/58	130	M 10	M 10	107	268	M 10	40	54	19,5 Kg	1,61 Kg

0 Choice of guide body profile:

- (0) Version with corrosion-protected components
- (1) Version 0 but with not corrosion-protected guidings

0 Choice of carriages:



Size	Version 0		Version 1	
	Q	L	Q	L
60	177	316	152	296
80	232	440	196	400
100	268	504	260	494

2 Drive version:

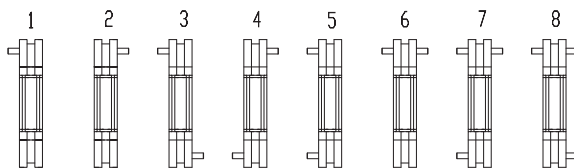

The standard version is supplied shaft pos. 2

Size	Shaft	
	R Key	S \varnothing h6 x length
60	5x5x28	14 x 35
80	6x6x40	18 x 45
100	6x6x40	22 x 45

Belt table

Code No.	Size	Belt	Pulley	
			mm/rev.	Number of teeth
0 3	60	5M25	130	26
0 4	80	8M30	176	22
0 7	100	8M50	224	28

Basic length + stroke = total length

QSIZE 80 1 0 0 2 0 4 1 01500

Pos. 1 2 3 4 5 6 7

Sample ordering code:

QSIZE80, standard body profile, standard carriage, shaft pos2, 1060 mm stroke

For additional accessories refer to main catalogue chapter 2.2 – 3.2

