

Positioning system UL 40, 60, 80

Roller guide unit without drive

Specifications

2.1

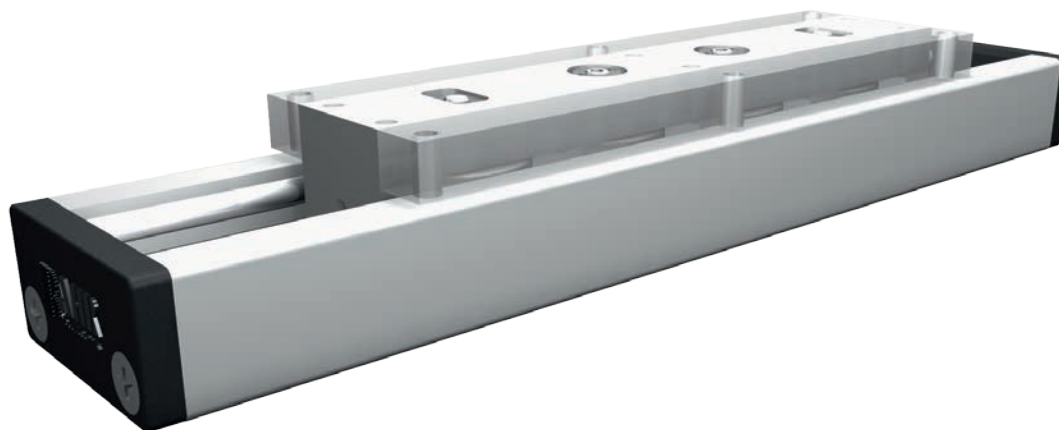

Function:

Very low building roller system achieved by an aluminium guide body with integrated, hardened steel guide rods. The carriage, which has internal linear ball bearings that can be adjusted free of play, moves along the body.

Fitting position: As required, max. length 6.000 mm.

Carriage connection: By tapped holes

Unit mounting: Afterwards by holes or tapped holes

Forces and torques	Size	UL 40		UL 60		UL 80	
	Forces/Torques	static	dynamic	static	dynamic	static	dynamic
	F_x (N)	-	-	-	-	-	-
	F_y (N)	1200	700	3000	2000	3000	2000
	F_z (N)	900	650	1700	1100	1700	1100
	M_x (Nm)	25	20	67	43	90	55
	M_y (Nm)	32	18	90	70	110	80
	M_z (Nm)	35	25	120	100	150	120
	All forces and torques relate to the following: existing values $\frac{F_y}{F_{y_{dyn}}} + \frac{F_z}{F_{z_{dyn}}} + \frac{M_x}{M_{x_{dyn}}} + \frac{M_y}{M_{y_{dyn}}} + \frac{M_z}{M_{z_{dyn}}} \leq 1$ table values						
Speed							
max. (m/s)		4		5		6	
Geometrical moments of inertia of aluminium profile							
I_x mm ⁴		0,157x10 ⁵		1,71x10 ⁵		2,8x10 ⁵	
I_y mm ⁴		0,654x10 ⁵		6,1x10 ⁵		10,59x10 ⁵	
E-Modulus N/mm ²		70000		70000		70000	

For life-time calculation of rollers use our CD-ROM or homepage!

Formula: UL

$$f = \frac{F \cdot L^3}{E \cdot I \cdot 192}$$

f = deflection (mm)
 F = load (N)
 L = free length (mm)
 E = elastic modulus 70000 (N/mm²)
 I = second moment of area (mm⁴)

Positioning system UL 40, 60, 80

Dimensions (mm)

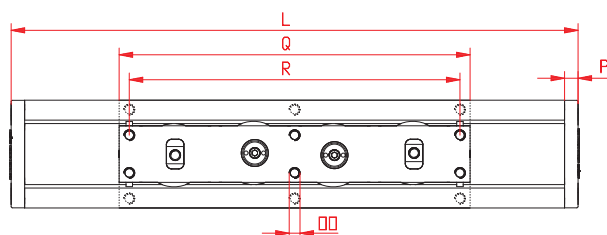
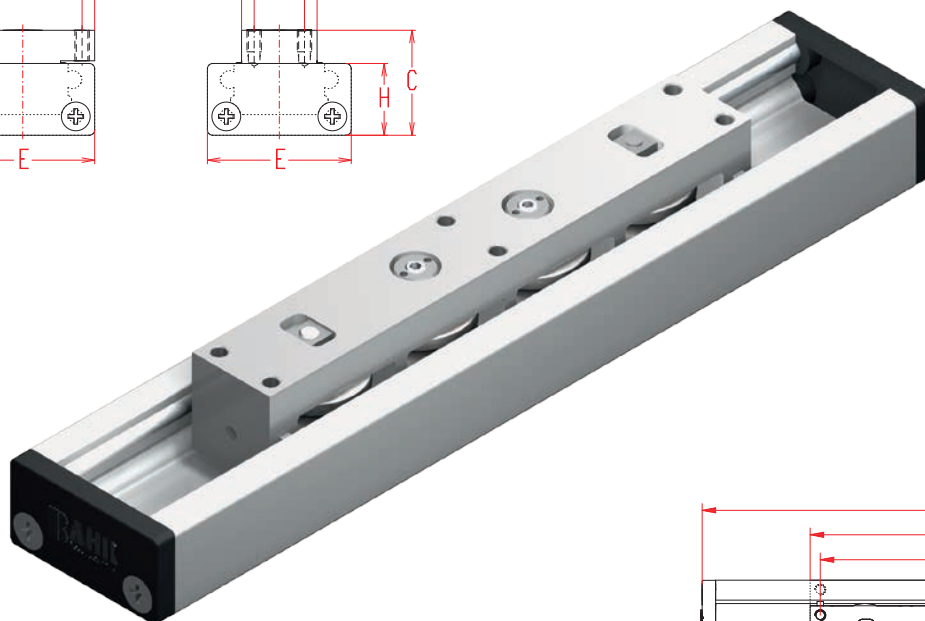
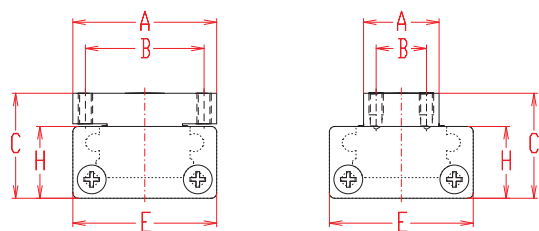

Size	Basic length L	A	B	C	E	H	OO for	P	Q	R	Basic weight	Weight per 100 mm
UL 40	160	40/20	31/13	33	40	22	M 5/M 5x8	6	146*	120	1,2 kg	0,13 kg
UL 60	215	60/29	48/20	43	60	30	M 6/M 6x10	8	194*	180	2,1 kg	0,20 kg
UL 80	285	80/42	66/28	58,5	80	40	M 8/M 8x12	10	260*	245	4,2 kg	0,48 kg

* = the carriage is not available in different lengths

0 Choice of guide body profile:

- (0) Standard
- (2) corrosion-protected guide rods and screws
- (4) expanded corrosion-protected version (depending on the availability of components)

0 Choice of carriage:

(0) Standard

(1) narrow carriage



1500 Basic length + stroke = total length

UL 40 0 0 0 0 0 0 0 0 0 1500

Pos. 1 2 3 4 5 6 7

For combination kits and connecting elements refer to chapter 2.2

Sample ordering code:

UL 40, non driven system, standard body profile, standard carriage (wide version), 1340 mm stroke